

# MASSACHUSETTS AVENUE BETTER BIKE PROJECT

November 12, 2020

# DESIGN PRIORITIES

---

- ▶ *Safety of people biking and walking*
- ▶ *Flow of buses, trucks, and cars*
- ▶ *Maintaining critical curb use*
- ▶ *Integration with ongoing planning and development*

# DESIGN PRIORITIES

---

- ▶ *Safety of people biking and walking*
  - *Reconstruction of ramps, new and realigned crosswalks*
- ▶ *Flow of buses, trucks, and cars*
- ▶ *Maintaining critical curb use*
- ▶ *Integration with ongoing planning and development*

# ISSUES WITH EXISTING CONDITIONS

- ▶ Existing crosswalk is not accessible for people using mobility devices
  - Ramps are not ADA compliant
  - Splitter island blocks the crosswalk
- ▶ Making this route accessible requires changes to private property



# RAMPS OPTION

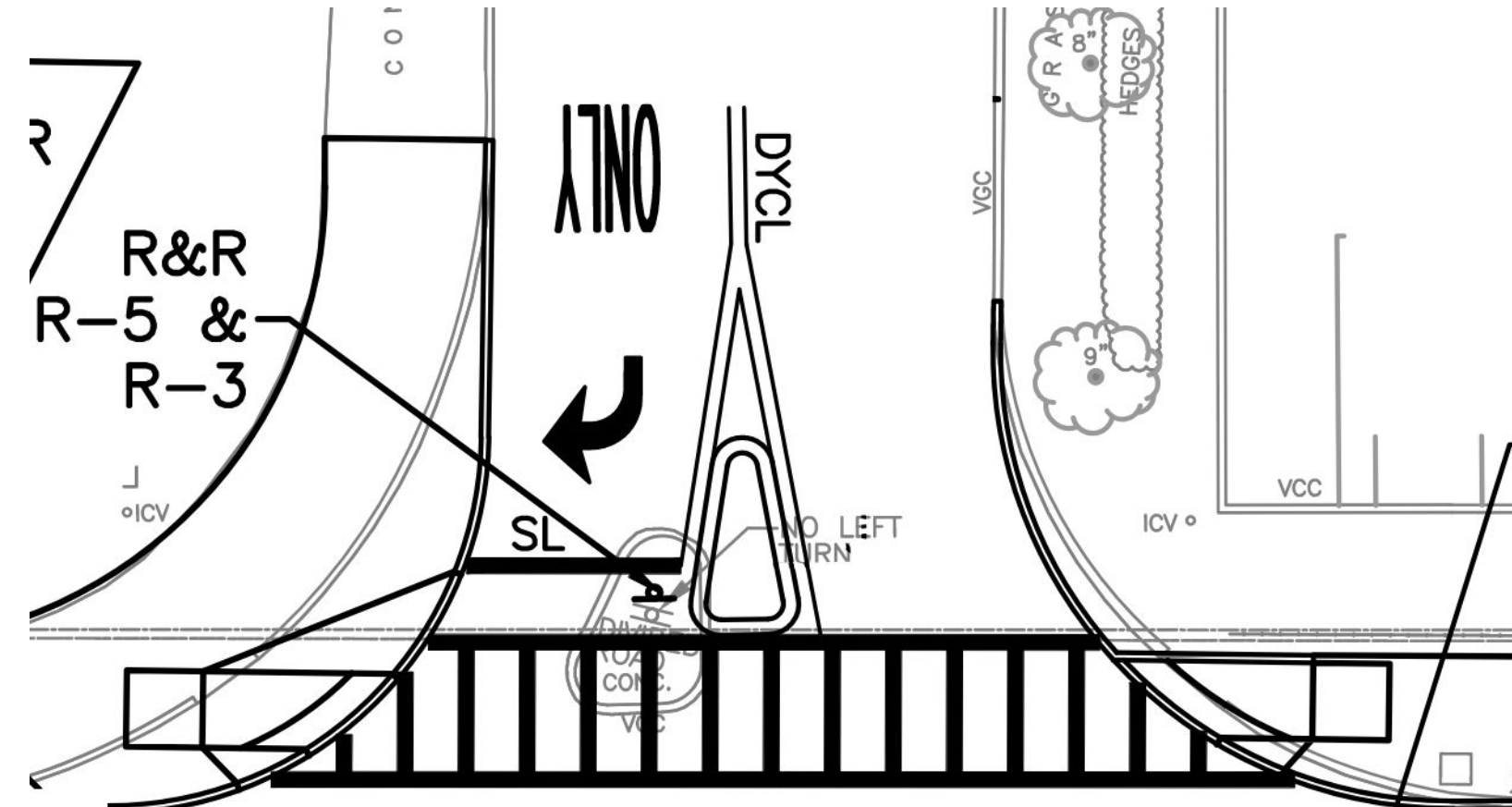

## Pros

- ▶ Preserves splitter island

## Cons

- ▶ People walking and using mobility devices must use two ramps to cross the driveway
- ▶ Ramps decrease useable sidewalk space
- ▶ Risk of leaf, snow, and water collection where the driveway meets the crosswalk

# DRIVEWAY APRON OPTION (PREFERRED)

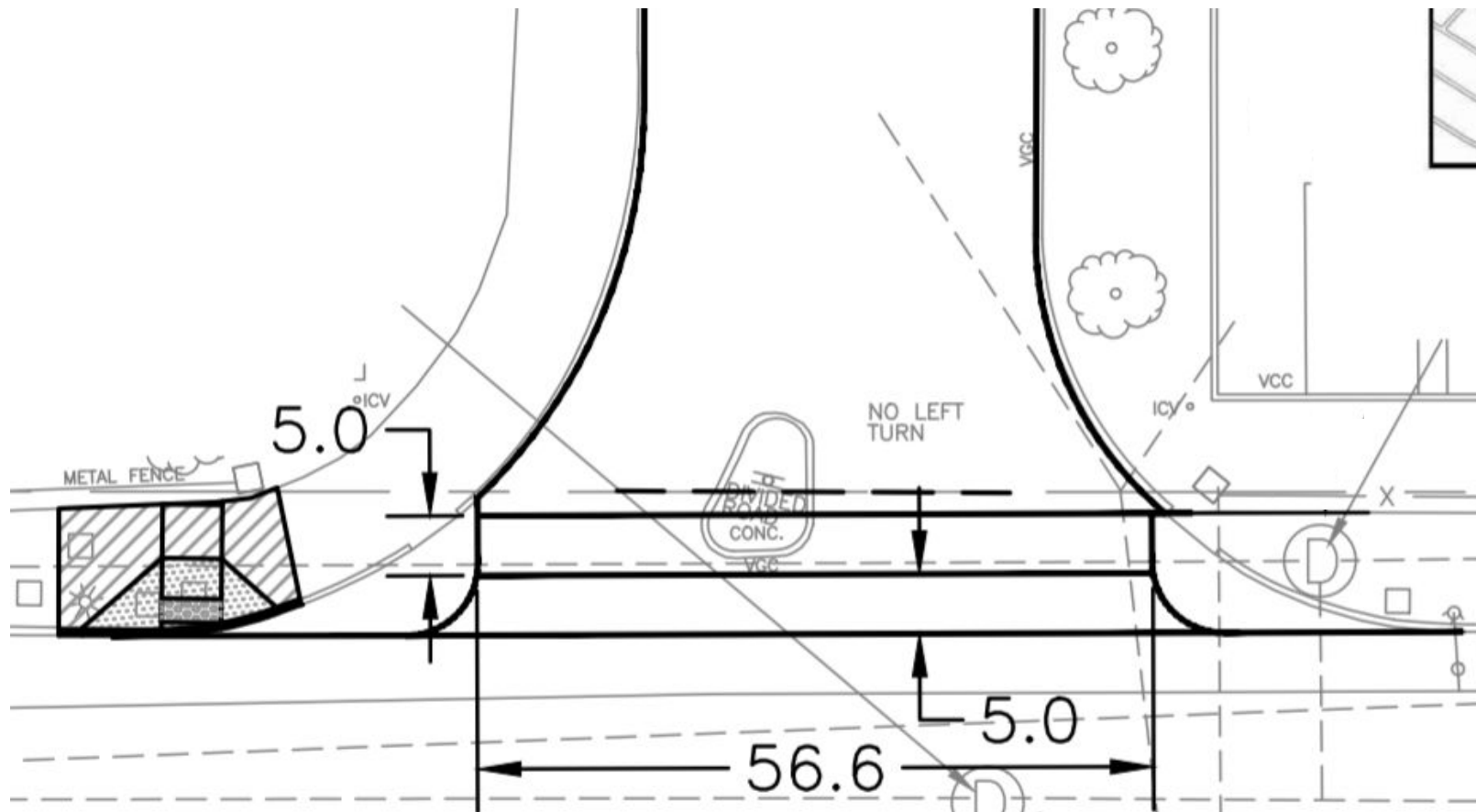

## Pros

- ▶ Level grade of crosswalk is easy for people walking, especially people using mobility devices
- ▶ Preserves maximum useable sidewalk space
- ▶ Less risk of leaf, snow, and water collection

## Cons

- ▶ Splitter island is not preserved

# DISCUSSION

---

- ▶ *Which option do you prefer we pursue?*
  - *If the ramps are preferred, we can share these plans with you and get moving on the easement.*
  - *If the driveway apron is preferred, we will need a few more weeks to develop the detailed drawings.*

*Note: we know you are waiting to see traffic analysis for this project. We will share that with you once we've completed internal reviews with our internal signals team.*